



Tyre Specifications

Manufacturer	BRIDGESTONE CORPORATION
Model / Type	WEK YFD 5.0/11.0-5
Number of Pages	4

This specification sheet is a reproduction of the illustrations and dimensions of the tyre tendered for approval. If this tyre is accepted the manufacturer will NOT modify in any way.



PHOTO OF TYRE

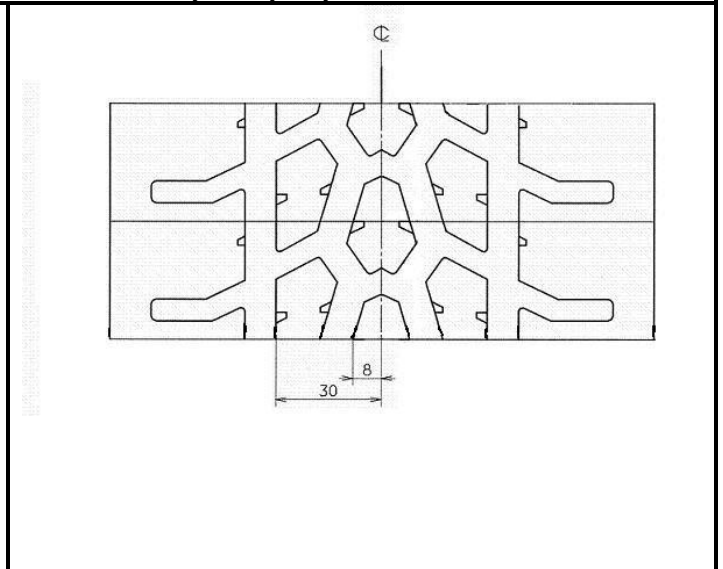

TREAD DESIGN DRAWING



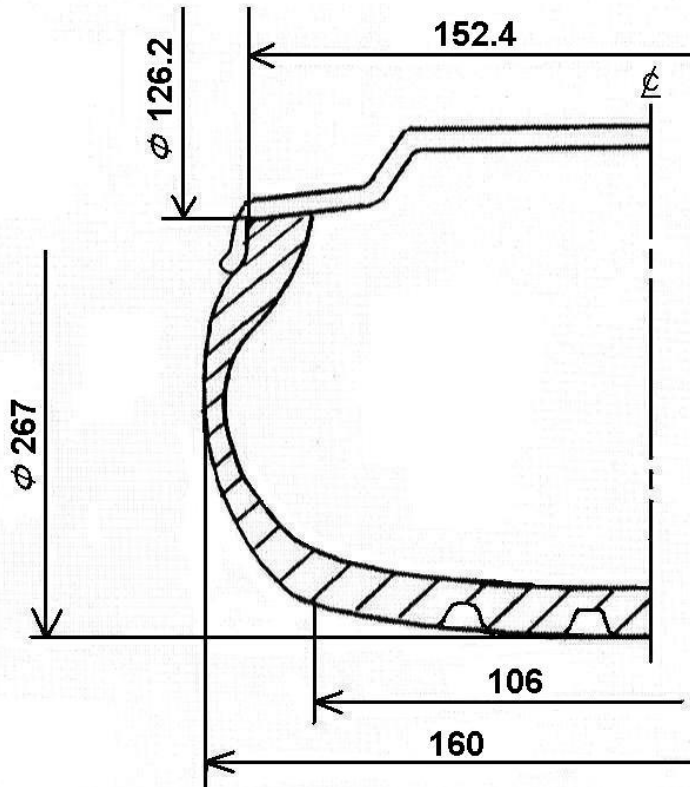

TECHNICAL INFORMATION	FACTS	TOLERANCES
Dimensions	5.0/11.0-5	-
Service pressure	1.0 bar	± 0.3 bar
Tread compound designation	YFD	-
Depth of tread	5.0 mm	+/- 0.5 mm
Weight	1200 g	+/- 10 %
Number of ply	2	-
Number of tread wear indicators	-	-
Maximum inflation pressure	4.0 bar	-
Carcass material	Nylon	-
Angle of tyre canvas	30°	+/- 3°
Canvass thread type (ISO)	940 dtex/2	-
Tread hardness	40	+/- 5
Tubeless tyre	Yes	-

Drawing of tyre cross section and ideal rim dimensions.



Tolerances	
160	± 5.0
106	± 5.0
267	± 7.0
126.2	± 0.3
152.4	± 1.0

Remarks

Photos and Inscriptions	Only inscriptions, which do not change during production, are mentioned.		
Photo of side wall – OUTSIDE	Inscriptions on side wall - OUTSIDE		
	Text 5.0/11.0-5 WEK TUBELESS MADE IN JAPAN YFD FOR RACING PURPOSE ONLY MAX. INFLATION PRESSURE 4.0 KG/CM2 (MOLD No.) BRIDGESTONE(PRINT) BAR CODE 	Height 6.3 mm 3.2 mm 4.0 mm 3.2 mm 5.0 mm 4.0 mm 4.0 mm 3.2 mm 18.0 mm 10.0 mm 8.0 mm	Stroke 2.0 mm 0.3 mm 0.5 mm 0.3 mm 0.5 mm 0.5 mm 0.5 mm 0.3 mm 2-6 mm 31.0 mm
Photo of side wall – INSIDE	Inscriptions on side wall - INSIDE		
	Text 5.0/11.0-5 WEK TUBELESS MADE IN JAPAN FOR RACING PURPOSE ONLY MAX. INFLATION PRESSURE 4.0 KG/CM2 (MOLD No.) BRIDGESTONE BAR CODE 	Height 6.3 mm 3.2 mm 4.0 mm 3.2 mm 4.0 mm 4.0 mm 3.2 mm 12.5 mm 10.0 mm 8.0 mm	Stroke 2.0 mm 0.3 mm 0.5 mm 0.3 mm 0.5 mm 0.5 mm 0.3 mm 2-5 mm 31.0 mm